

FLOW CONTROL VALVES

VFD SERIES FLOW DIVIDER VFD

◆ MODEL VFD

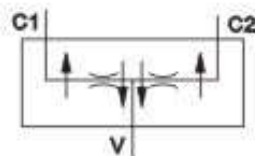
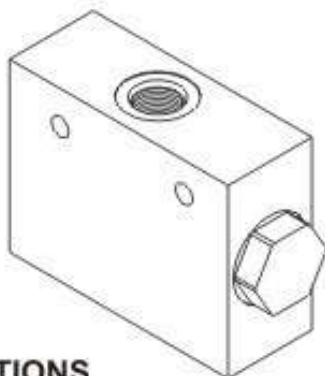

◆ SPECIFICATIONS

Model Number 型式號碼	Operating Pressure 操作壓力 bar	Flow 流量 lpm	Weight 重量 Kg
VFD-03	250 (3626 psi)	45 (11.89 gpm)	0.6 (1.32 lbs)
VFD-04	210 (3046 psi)	38 (10.04 gpm)	0.8 (1.76 lbs)
VFD-05	250 (3626 psi)	90 (23.78 gpm)	2.05 (4.52 lbs)
VFD-06	250 (3626 psi)	194 (51.25 gpm)	2 (4.40 lbs)
VFD-08	250 (3626 psi)	194 (51.25 gpm)	2 (4.40 lbs)

◆ HOW TO ORDER

1	2	3	4
VFD	03	— 07	— *

4 THREADED TYPE

1P: PT 2N: NPT
3G: PF(G) 4A: SAE

1 VALVE SERIES 系列名稱
VFD = FLOW DIVIDER Valves 分流閥

2 SUBPLATE MOUNTING SIZE 轉印口徑
03 : G 3/8 04=1/2" 05 : G 3/4 06=3/4" 08=1"

3 FLOW SPECIFICATIONS 流量規格

03 : 07: 2.3~7.6 l/min
15: 4.5~15 l/min
22: 6.8~22.7 l/min
30: 9~30 l/min
37: 11~37 l/min
45: 13.5~45 l/min
Division or combination ratio 50% - 50%

04 : 11: 6.5~11 l/min 25: 10~25 l/min
38: 25~38 l/min

05 : 60: 30~60 l/min
70: 43~74 l/min
90: 53~90 l/min

06 : 90: 90 l/min 110: 110 l/min
150: 150 l/min 190: 194 l/min

08 : 90: 90 l/min 110: 110 l/min
150: 150 l/min 190: 194 l/min